

深圳市晶泰源电子有限公司

2SC2120 TRANSISTOR(NPN)

MAXIMUM RATINGS(Ta=25°C unless otherwise noted)

Symbol	Parameter	Value	Units
VCBO	Collector-Base Voltage	35	V
VCEO	Collector-Emitter Voltage	30	V
VEBO	Emitter-Base Voltage	5	V
IC	Collector Current	0.8	A
PC	Collector Power Dissipation	600	mW
Tj	Junction Temperature	150	°C
Tstg	Storage Temperature	-55~150	°C

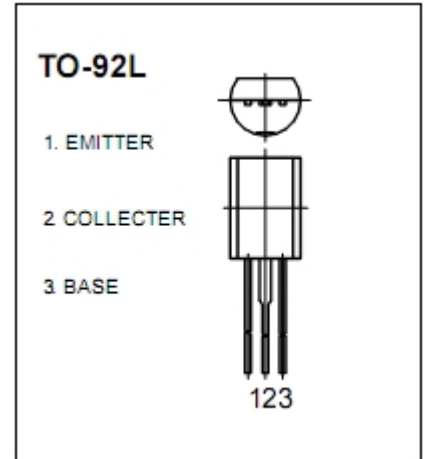

ELECTRICAL CHARACTERISTICS(Tamb=25°C unless otherwise specified):

Parameter	Symbol	Test conditions	MIN	TYP	MAX	UNIT
Collector-base breakdown voltage	V(BR)CBO	IC=100uA, IE=0	35			V
Collector-emitter breakdown voltage	V(BR)CEO	IC=1mA, IB=0	30			V
Emitter-base breakdown voltage	V(BR)EBO	IC=100uA, IC=0	5			V
Collector cut-off current	ICBO	VCB=35V, IE=0			0.1	μA
Emitter cut-off current	IEBO	VEB=5V, IC=0			0.1	μA
DC current gain	HFE	Vce=1V, Ic=100mA	100		320	
Collector-emitter saturation voltage	VCE(sat)	IC=500mA, IB=20mA			0.5	V
Base-emitter voltage	VBE	VCE=1V, IC=10mA	0.5		0.8	V
Transition frequency	fT	VCE=5V, IC=10mA		120		MHZ
Collector output capacitance	Cob	VCB=10V, IE=0, f=1MHz		13		pF

深圳市晶泰源电子有限公司
电话：0755-83211536 传真：0755-83206326
深圳市福田区华强北路华强广场C座11C